

# EMERGENCY LED GAS STATION LIGHTS



## CONSTRUCTION & MATERIALS

- Dia-casting aluminum alloy housing, fully sealed to be dirt and bug proof
- Shock-proof polycarbonate refractor with UV inhibitors
- IP 65 & IK10 rating
- Over-current/temperature, Short/open circuit protection with auto-reset
- Built-in UL approved emergency battery backup

## MOUNTING AND WIRING

- Three 3/4" mounting holes plus one on top for mounting. One installation bracket with screws are supplied in package

## ENVIRONMENTAL SYSTEM

- Outdoor wet/damp location

## FINISH

- Bronze

## ELECTRICAL SYSTEM

- Input voltage 100-277VAC, 50/60Hz
- ETL/cETL/CE/Rohs, DLC Premium

## OPTICAL SYSTEM

- 120 LPW
- Color temperature: 3000K, 4000K, 5000K, 5700K.

## LIGHTING CONTROL

- >90min. discharge emergency time
- Motion sensor
- Photocell

## WARRANTY

5 Years

# EMERGENCY LED GAS STATION LIGHTS

Emergency LED gas station lights provide dia-casting aluminum alloy heat sink and high shock-proof polycarbonate refractor. UL/CE approved emergency battery back offers more than 90 min. emergency time. DLC premium and 5 years warranty is available. Motion sensor and photocell sensor can be suitable for parking garage, warehouse, mail, office and others.

## Performance

**Light Output:** 120 lumens per watt  
**Input Power:** 40/60/90 watts  
**Input Voltage:** 100-277vac  
**CCT:** 3000K, 4000K, 5000K, 5700K  
**Discharge time:** >90 min.  
**Charging cycles:** >500  
**Charging time:** 24 hrs.  
**EMC/FCC/IC Std.:** EN55015, EN61547, EN61000-3-2/3, FCC part 15, ICES-005  
**Safety Std.:** EN61347-1, EN61347-2-7, UI924, CSA C.22.2 NO. 141  
**Certificate :** ETL/CETL/CE certified, DLC premium  
**Weight:** 5.5 Kg

## Refractor Option



**Low Profile**  
**(ETL/cETL**  
**DLC PREMIUM)**



**High Profile**  
**(ETL/cETL)**

## Dimension (Low Profile)

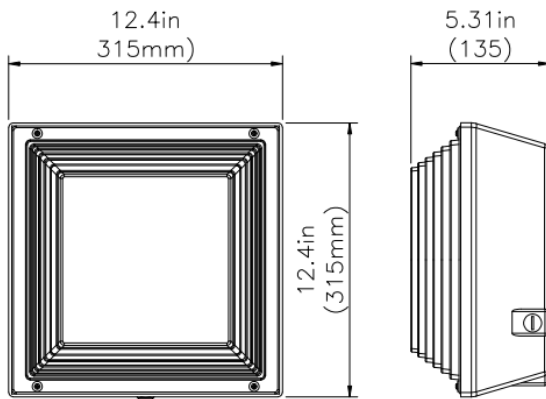

## Light Distribution

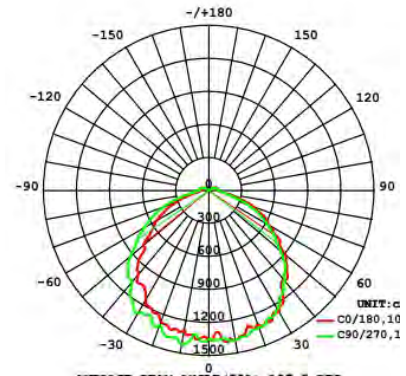

## Order Information

Sample Number: LT-SGSAL-40W-HV-30K-EM

Com.	Family Name	Cover Type	Watts	Voltage	CCT	Finish	Control Mode
LT Lightide	<b>SGSA</b> Square Gas Station Light Type A	H=High L=Low	<b>40W</b> <b>60W</b> <b>90W</b>	Blank=100-277VAC	<b>30K=3000K</b> <b>40K=4000K</b> <b>50K=5000K</b> <b>57K=5700K</b>	Blank=Bronze	<b>DM=0-10VDC Dimming</b> <b>PC=Photocell</b> <b>MS= Motion sensor</b> <b>EM= Emergency</b>

MORE QUALIFIED PRODUCTS, PLEASE CONTACT

Email: [sales@lightide-tech.com](mailto:sales@lightide-tech.com)  
<https://www.lightide-tech.com>  
 Lightide Manufactory Co., Ltd | Lightide HK Industrial Co., Limited  
 All right reserved.



**LIGHTIDE** 